



720-730nm Narrow Linewidth Laser

Based on high-power, low-noise fiber lasers amplification and sum-frequency technology, Precilasers can provide high-power, narrow linewidth laser output with a wavelength ranging from 720 to 730 nm.

Features

- Narrow Linewidth
- Low RIN
- High Power
- Power Stability: $<0.75\%_{rms}$, 3hrs
- Excellent Beam Quality ($M^2 < 1.1$)
- Never Mode-hop
- High Temperature And Vibration Resistance

Application

- Quantum Simulation



Specification				
Partnumber	FL-SF-XXXX-YY-CW ⁽¹⁾			
Wavelength Range	720-730nm			
Typical Wavelength	729nm			
Operation Mode	CW			
Output Power	> 0.5W	> 2W	> 5W	> 8W
Thermal Tuning Range	> 0.2nm, Never Mode-hop			
Output Mode	Free Space Output			
Beam Diameter	0.7-1.0mm			
Linewidth ⁽²⁾ (100us)	< 20kHz			
PER	> 20dB			
Power Stability	< 0.75%@3hours, RMS			
Beam Quality	$M^2 < 1.1$			
PZT Frequency Tuning Range	> 3GHz			
PZT Frequency Tuning Bandwidth	> 5kHz			
Fast Frequency Tuning Range	> 500MHz			
Fast Frequency Tuning Bandwidth	> 1MHz			
AOM Tuning Range (Optional)	> ± 5 MHz			
AOM Tuning Bandwidth (Optional)	> 500kHz			
RIN	< 0.08% (10Hz-100MHz, RMS)			
Cooling	Air Cooling/Water Cooling			
Operating Environment & Power Supply				
Temperature	15-30 °C (Air Cooling) or 15-35 °C (Water Cooling)			
Power Supply	100V-240V, AC, 50/60Hz			
Communication	RS422			

(1)XXXX is the laser center wavelength, YY is the laser power, for a 0.5W 729nm laser,the partnumberis FL-SF-729-0.5-CW

(2)Measured by self-hetrodyne method

Air Cooling Control Unit Dimension

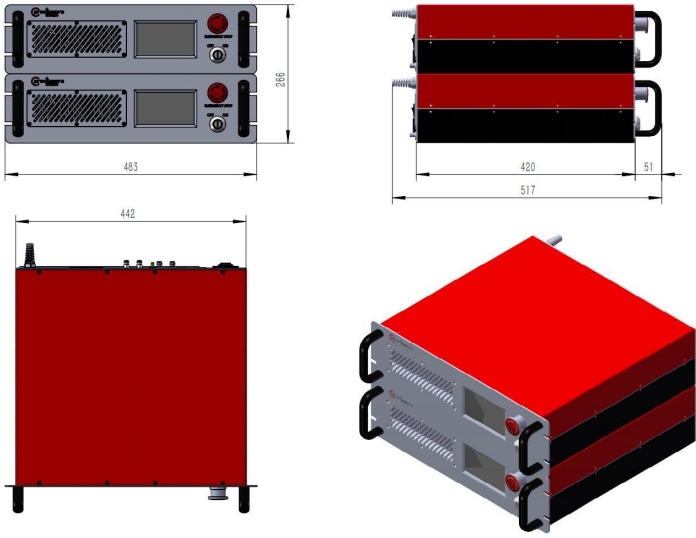

Tm-Doped Fiber DFB Seed Laser (Air Cooling)

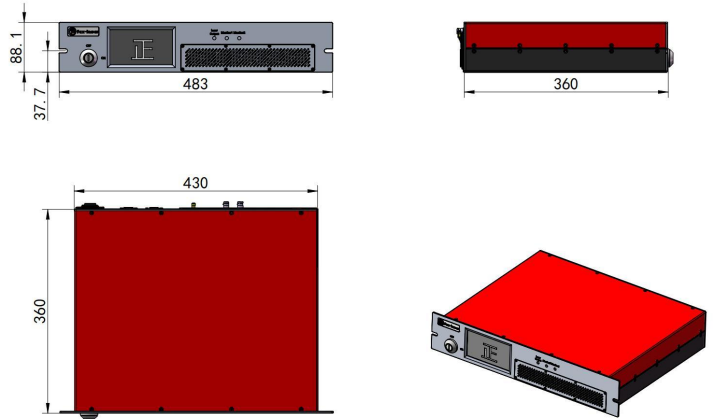

Laser Head Output Dimension

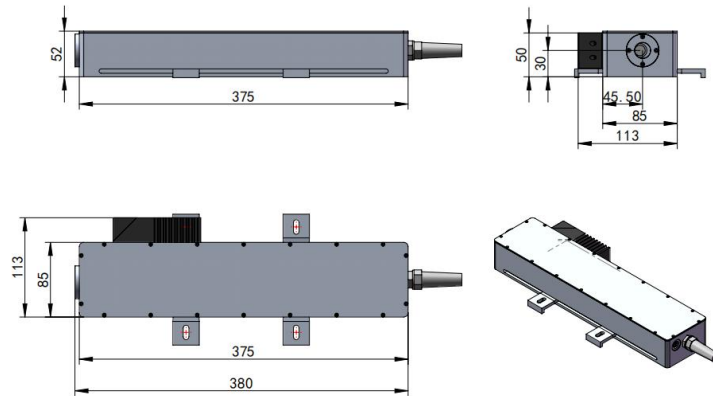

Water Cooling Control Unit Dimension

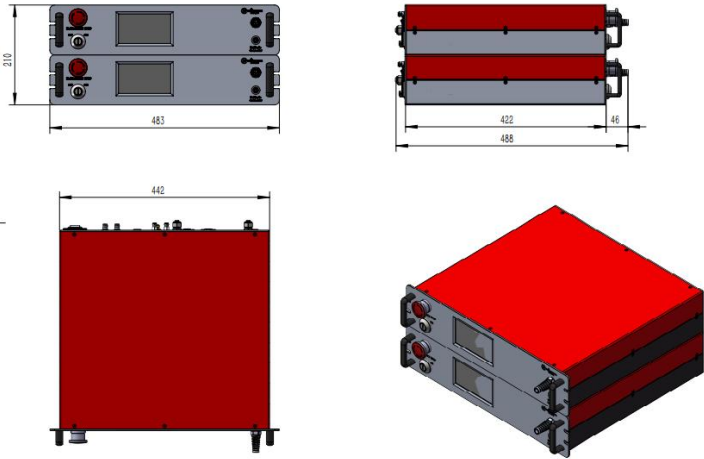

Tm-Doped Fiber DFB Seed Laser (Water Cooling)

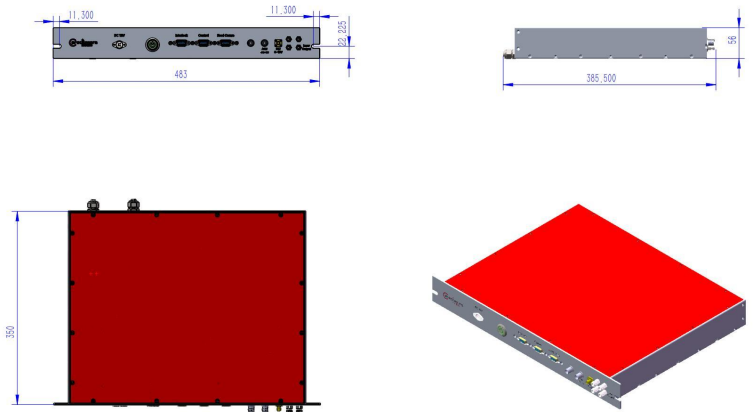

Laser Head Output Dimension

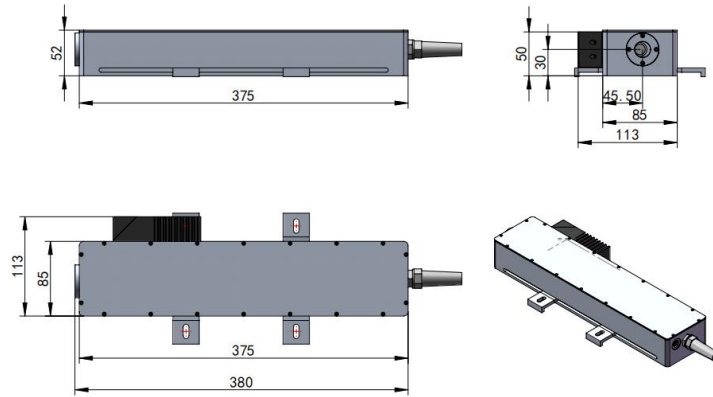

ShanghaiPrecilasersTechnologyCo.,Ltd.
 Floor2,Building2,No.1918,XupanRoad, JiadingDistrict,Shanghai
 021-59160265

info@precilasers.com

www.precilasers.com



⚠ DANGER

VISIBLE AND INVISIBLE LASER RADIATION
 AVOID EYE OR SKIN EXPOSURE TO
 DIRECT OR SCATTERED RADIATION
 CLASS 4 LASER PRODUCT

